



**FLASHCHEF™**  
**High Speed Oven**

G1-1





**FLASHCHEF™**  
**Professional Kitchen series**

Born to be professional. Midea FlashChef™, an extensive lineup of professional cooking appliances that focuses on the needs of most commercial environments: efficient, easy and durable.

Compared to ordinary cooking appliances, FlashChef™ offers remarkable performance contributed to the redesigned structures, tailor-made components and enhanced interiors.

From convenience stores, office pantries or café, to commercial kitchens, chain stores or stadiums, FlashChef™ will surely meet and surpass your high expectation with its ultra-efficient performance, effortless operation and impressive durability.



**Midea**  
**FLASHCHEF™**  
**High Speed Oven**

**2 color options**

Black stainless steel and stainless steel, 2 color options to adapt to more kitchen designs



# Cooking functions

Convection, Grill, and Microwave functions



Microwave functions



Grill functions



Convection functions



## DUAL IMPINGEMENT DUAL EFFICIENCY

For the ever first time, FlashChef™ High Speed Oven is equipped with duo-impingement system that significantly speeds up the cooking. Compared to traditional HSO that heats the food with impingement from the top, while convection from the bottom, FlashChef™ High Speed Oven simultaneously ejects impingement from both top and bottom. The result? Ultra fast browning and crisping on both side of the food in a flash!

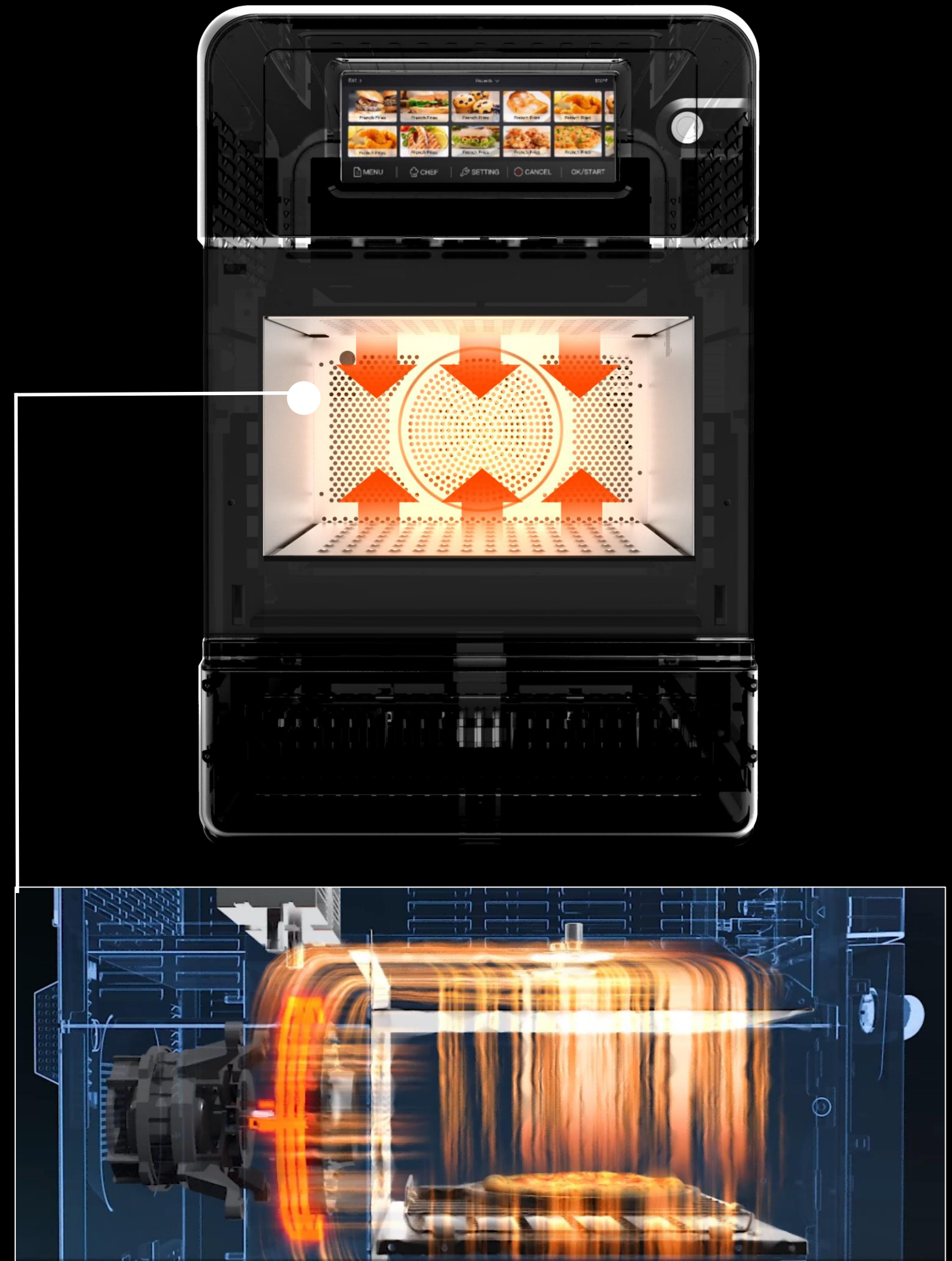

# IMPINGEMENT

Convenient Efficiency vs. Typical High Speed Oven: +8%

Dual Magnetron with Inverter Technology vs. Conventional Microwave Oven System: +25%

Cooking Speed vs. Conventional Ovens: 20 Times Faster

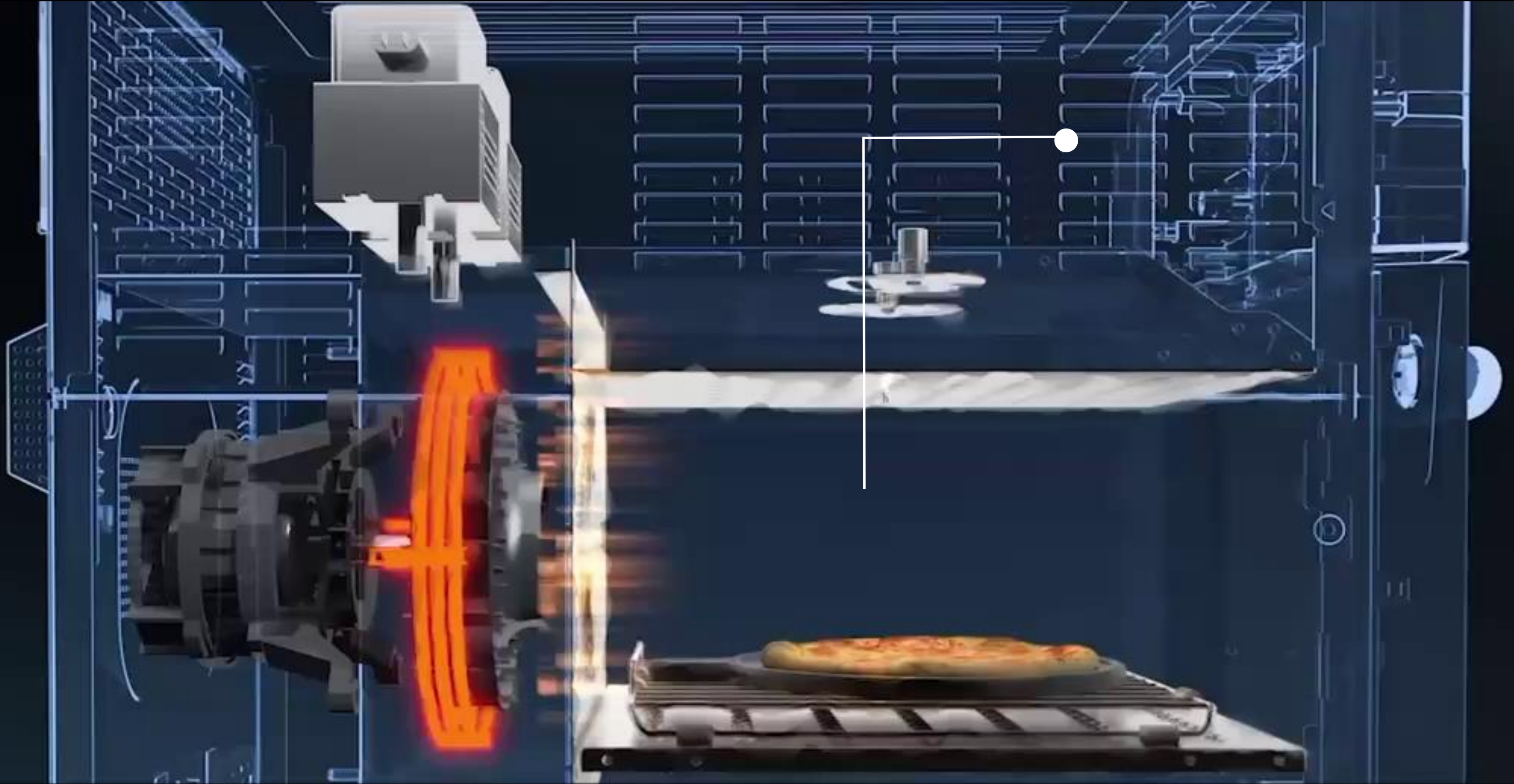



## INVERTER ENABLED PERFECT FOOD ACHIEVABLE

With built-in inverter technology, FlashChef™ High Speed Oven is the first in the industry with such equipment.

Heat can be delivered uniformly to prevent over-heated or under-heated, thanks to the precise control and automatic power adjustment brought by inverter technology.





## HEAT WITH ULTRA-SPEED DUO-MAGNETRON DESIGN

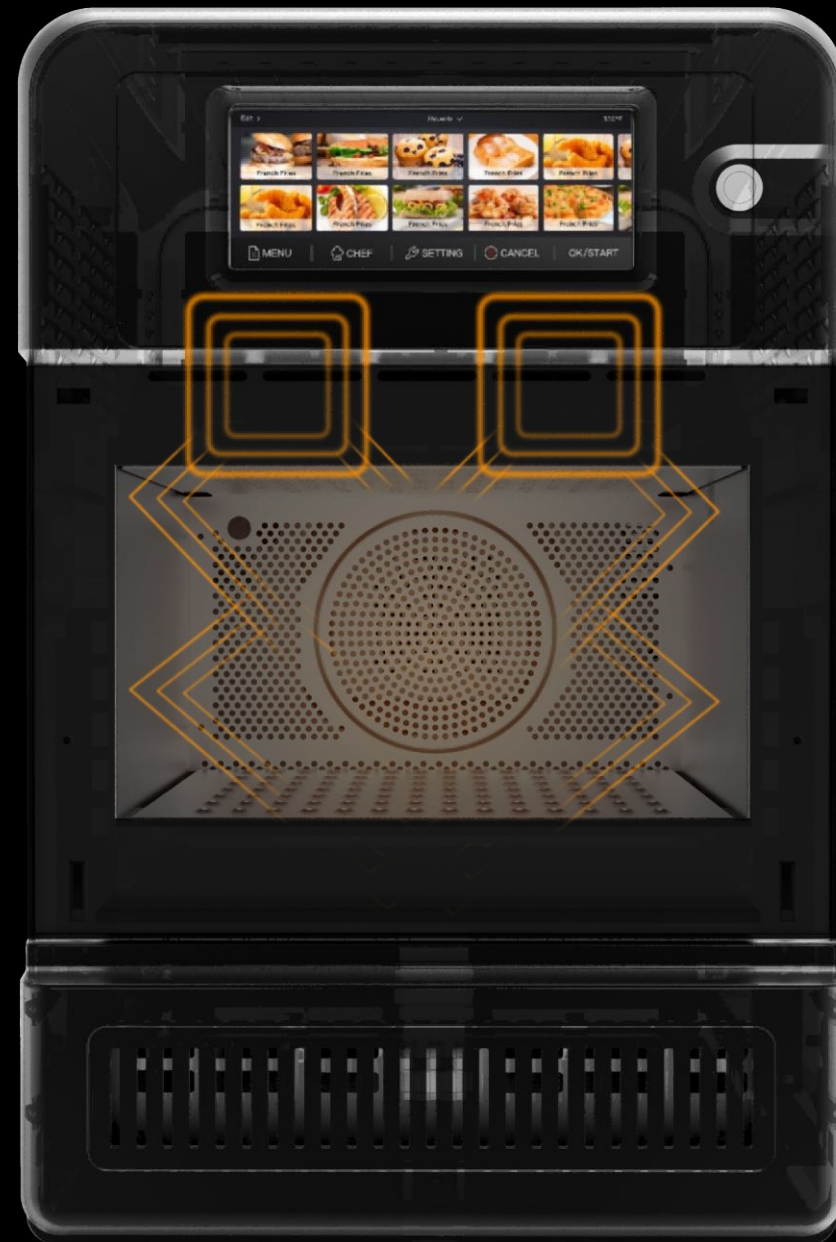

FlashChef™ High Speed Oven contains two magnetrons that speed up the cooking with up to 1000 watt microwave power output, saving up the heating time with outstanding efficiency.





## 6-STAGES COOKING MORE FLEXIBILITIES , MORE POSSIBILITIES

Up to 6 stages of cooking, FlashChef™ High Speed Oven allows the user to control which way to cook, and how much energy shall be delivered within the food throughout a cook cycle, offering more possibilities for the masterpiece.

Pizza-Stage Cooking

IMAGE  TEMPERATURE(200°F-520°F)  520°F ▼

TIME  IMPINGEMENT  MICROWAVE 

TIME	IMPINGEMENT	MICROWAVE
02:15	STAGE 1 100%	40%
00:10	STAGE 2 40%	80%
00:20	STAGE 3 60%	30%
00:20	STAGE 4 50%	50%
00:15	STAGE 5 50%	30%
00:15	STAGE 6 100%	10%

## 7.84" HD TFT TOUCH SCREEN

7.84"HD TFT touch screen, largest screen in its class for easier reading.



## BUILT-IN CAVITY LIGHT

Check the food status without even taking it out from the cavity with FlashChef™ High Speed Oven built-in cavity light. Brighter and clearer sight inside for perfect cook.

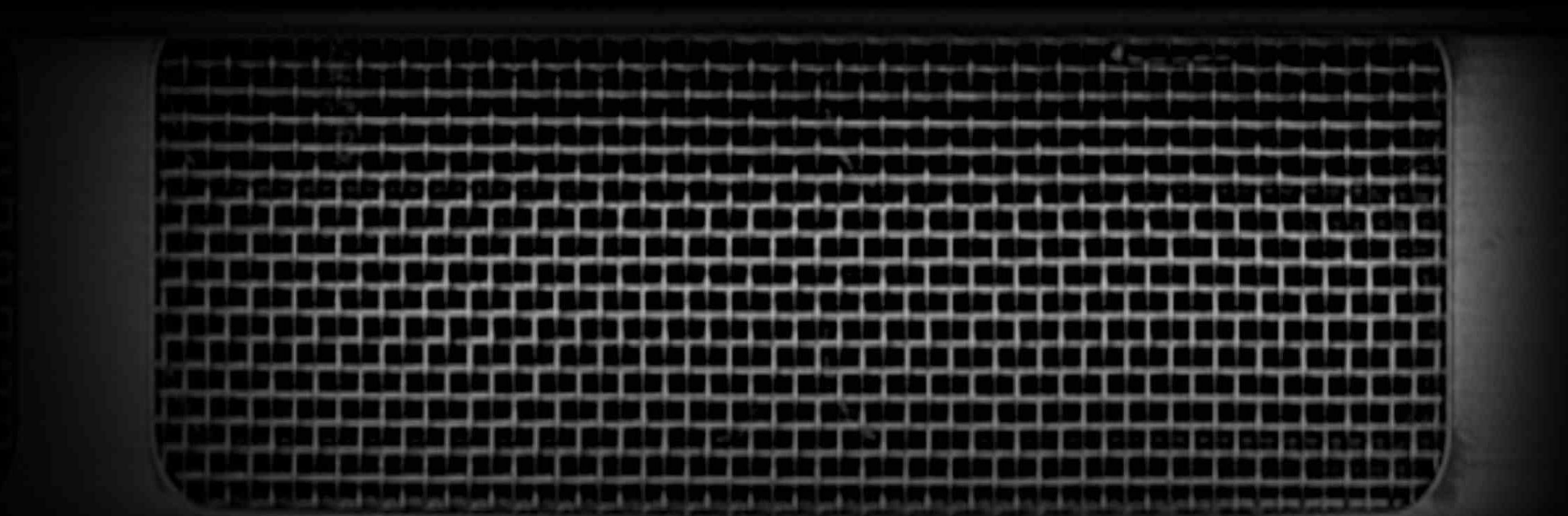

## PRESS 'N EJECT AIR FILTER

The air filter is securely fixed by special design component. It can be detached simply by pressing, for easy cleaning.

## LARGER CAVITY FOR HIGHER FLEXIBILITIES

FlashChef™ High Speed Oven has a large cavity that accommodates a 12" (30cm) pizza with ease.

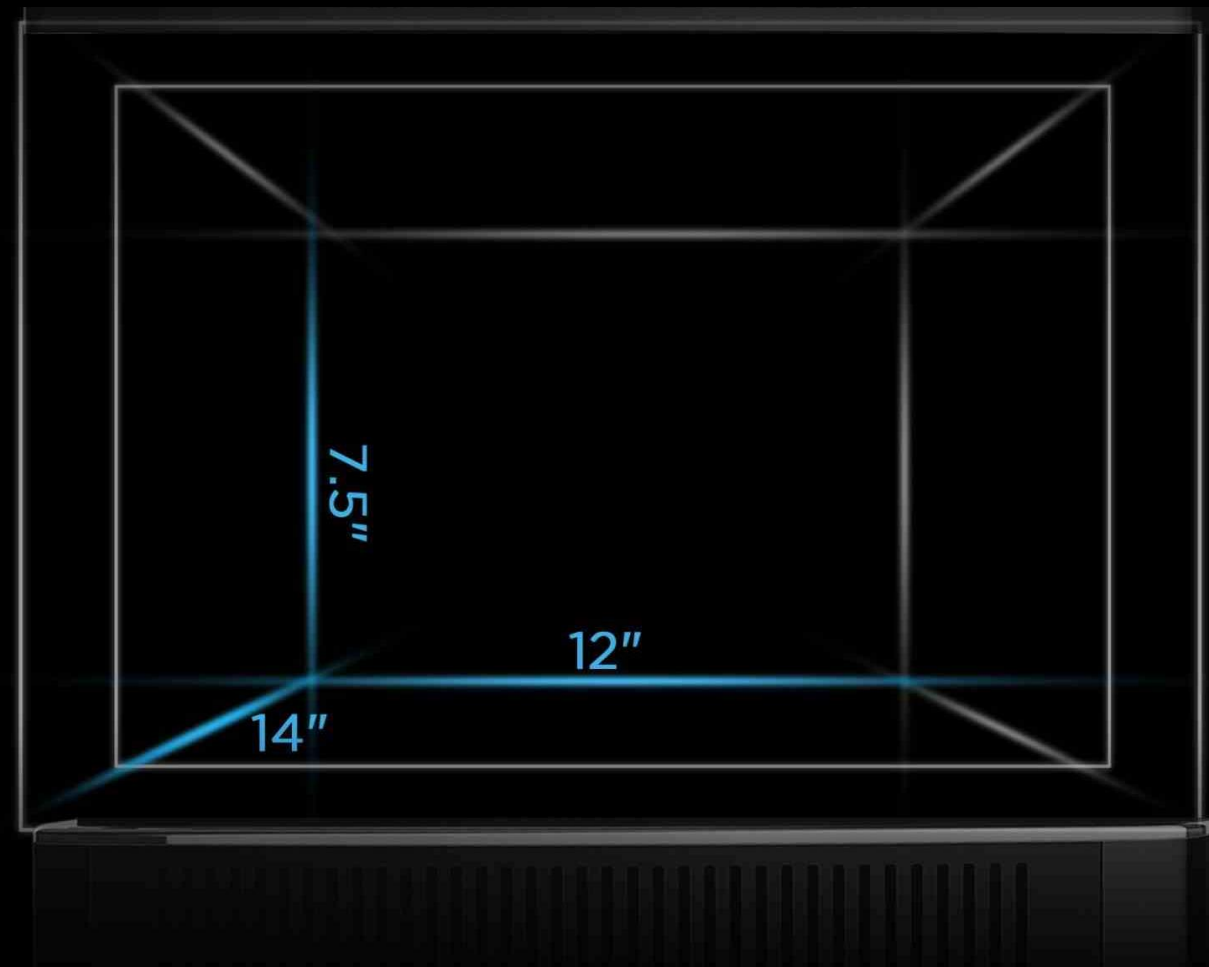

## SPACE-FRIENDLY FOOTPRINT

Fits into various places with a space-friendly footprint.



## STAINLESS STEEL FINISH FOR ULTIMATE DURABILITY

Built with stainless steel, FlashChef™ High Speed Oven meets the challenge of complicated commercial environment, for ultimate durability.

## IDEAL MATCHING WITH MULTIPLE COLORS

FlashChef™ High Speed Oven provides 2 different colors that matches different environment ideally: from classic silver, to modern black.



Silver



Black



Fetch Handle



Stainless steel shovel

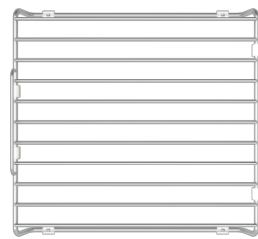

Rack

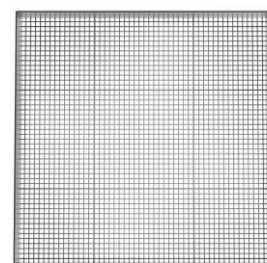

Teflon baking nets

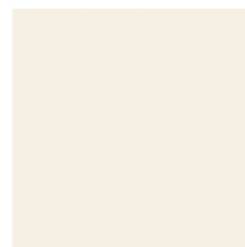

Release paper

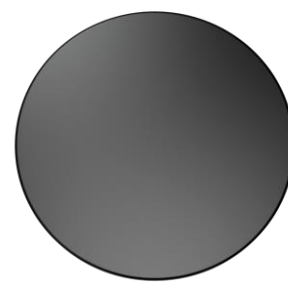

Pizza Stone



Midea FlashChef™ High Speed Oven provides incredible performance where professional cooking results are needed. With breakthrough dual impingement system. Midea FlashChef™ High Speed Oven can brown and crisp with ultra-fast speed. Dual magnetrons with inverter® technology enables the Midea G1-1 to cook or heat the food quickly and uniformly while consuming less energy. Apart from its impressive performance, Midea FlashChef™ High Speed Oven is user-friendly. 7.8"HD TFT touch screen, largest screen in its class, offers the user more content with clearer display. The intuitive and scrollable control panel with auto-top menu function provides phone-like operation, eliminating operating and language barriers. Built-in cavity light allows the users to check the food with brighter view. With these features and functions, the Midea FlashChef™ High Speed Oven adapts to many different applications for users and operators and includes R&D Chef Support.

# Model: G1-1

## Main Features

### Outstanding Cooking Performance

- + Dual impingement for ultra-fast browning and crisping on both sides of the food.
- + Dual magnetrons for high and consistent power output to save heating time.
- + Inverter Technology for the best microwave oven control.
- + Precisely control and adjust power for proper heating.
- + 6 cooking stages for more flexible and versatile applications.

### User Friendly Operation

- + 7.8"HD TFT touch screen, largest screen in its class for easier reading.
- + Intuitive icon control panel eliminates language barriers, just like operating a phone.
- + Auto-top menu function intelligently puts the frequently-use menu groups on top, for instant and convenient access.
- + Built-in cavity light provides brighter and clearer sight inside the interior.

### Stylish Appearance

- + Large cavity accommodates a 12" (30cm) pizza with space-friendly footprint.
- + Stainless steel finish for easy maintenance and great appearance.

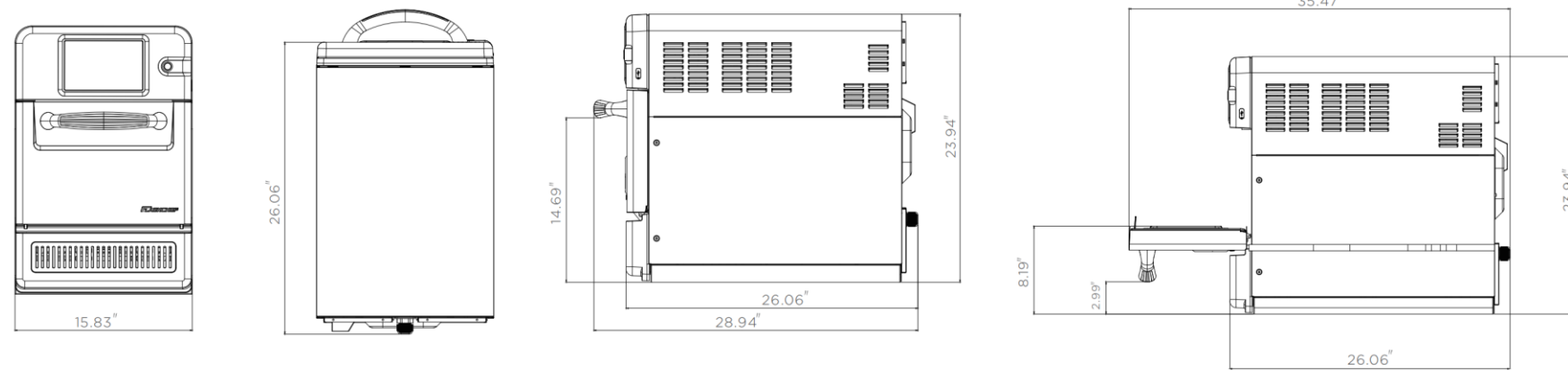

Top: 11" (300), Sides: 3" (100), Back: 3" (100)



Model	G1-1
<b>Dimensions</b>	
Cavity Size (Liter/cu.ft.)	0.66 cu.ft (18.7 Liters)
Cavity Interior	SUS 304
Cavity Dimension (WxDxH)	314 mm x 343 mm x 175 mm (12.4"×13.5"×6.9" inches)
Product Dimensions (WxDxH)	404 mm x 734 mm x 607 mm (15.9"x28.9"x23.9" inches)
Package Dimensions (WxDxH)	474 mm x 858 mm x 750 mm (18.7"x33.8"x29.5" inches)
Net Weight	60 kg (132 lb)
Gross Weight	67 kg (147 lb)
Loading Capacity (20' / 40' / 40' HQ)	96 / 195 / 195 Pcs
<b>Electrical specifications</b>	
Electrical Power (Max)	3000W
Microwave Output Power (Inverter)	1000W
Impingement Power	3000 W 525°F
Supply Voltage	230 V, 50Hz
Amps	16A
Plug Type	
Plug Image	UL/ VDE
<b>Technical Specifications</b>	
Control Type	7.8"HD TFT Touch Screen
Temperature Range	200° F-527° F ( 93° C-275° C ), 1F Increments
Microwave Power Levels	0% to 100% in 1% Increments
Fan Power Levels	0% to 100% in 1% Increments
Auto Program	1024, Over 10 Categories
Stage Cooking	6 (Max.)
Max. Cooking Time	00:60:00-10:00 Min Per Stage
Connectivity	USB
<b>Certifications/Hoodless Cooking</b>	
UL+FCC+FDA+UL EPH+Ventles+EMC+CE	

